

Desarrollo de un sistema criogénico con Neón líquido para la caracterización de superconductores

Dr. Marco Bianchetti

Universidad de Guanajuato

Departamento de Estudios Multidisciplinarios

Trabajo realizado en la Universidad de Southampton, UK

Neon Liquefier System

Temp. K	Pressure atm
25	0.511
27.09	1.013
28	1.322
30	2.238
32	3.553
34	5.352
36	7.728
38	10.782
40	14.525
42	19.386

Expansion liquid → gas: 1600 times

PG: Pressure Gauge

NRV: Non Return Valve $\Delta P=1.2\text{bar}$

SV: Shut Valve

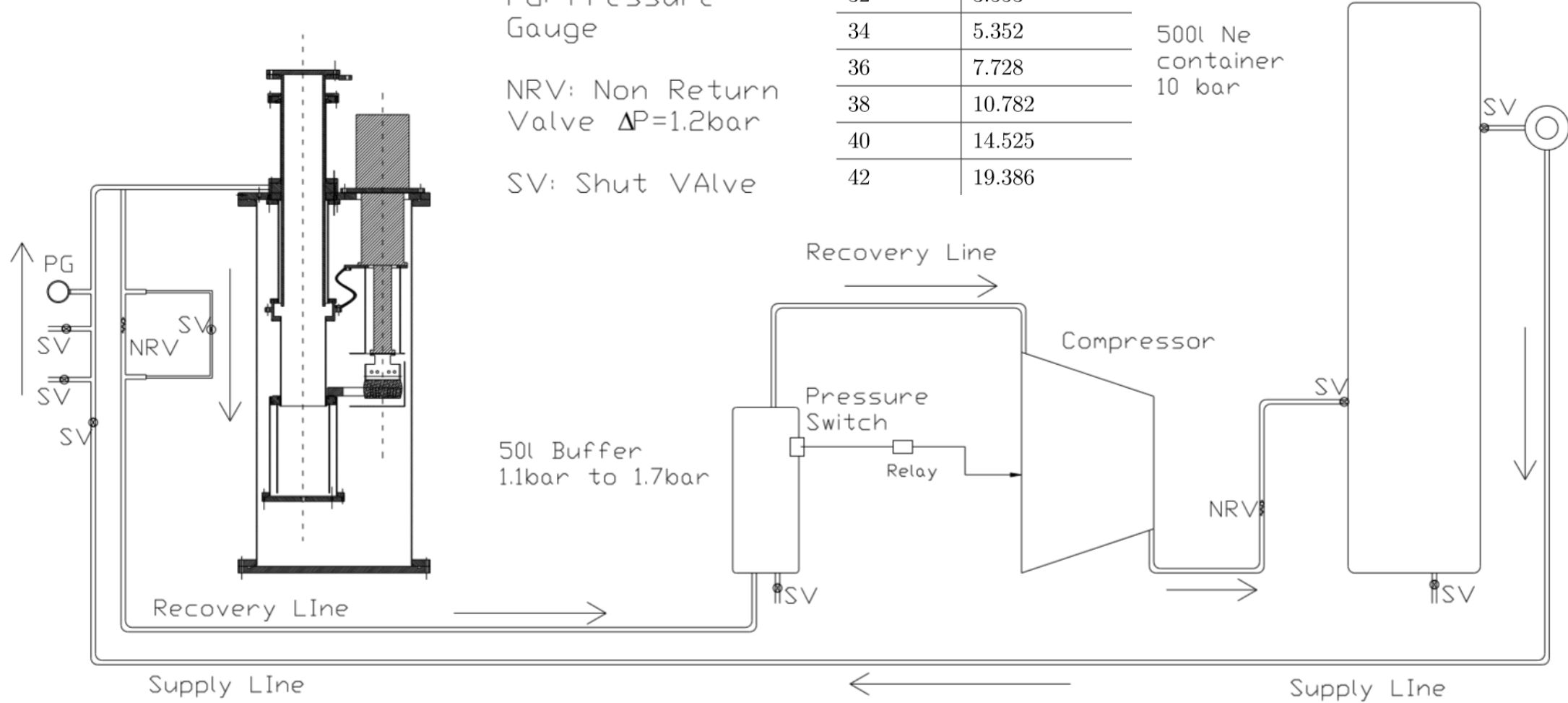

Neon Cryostat

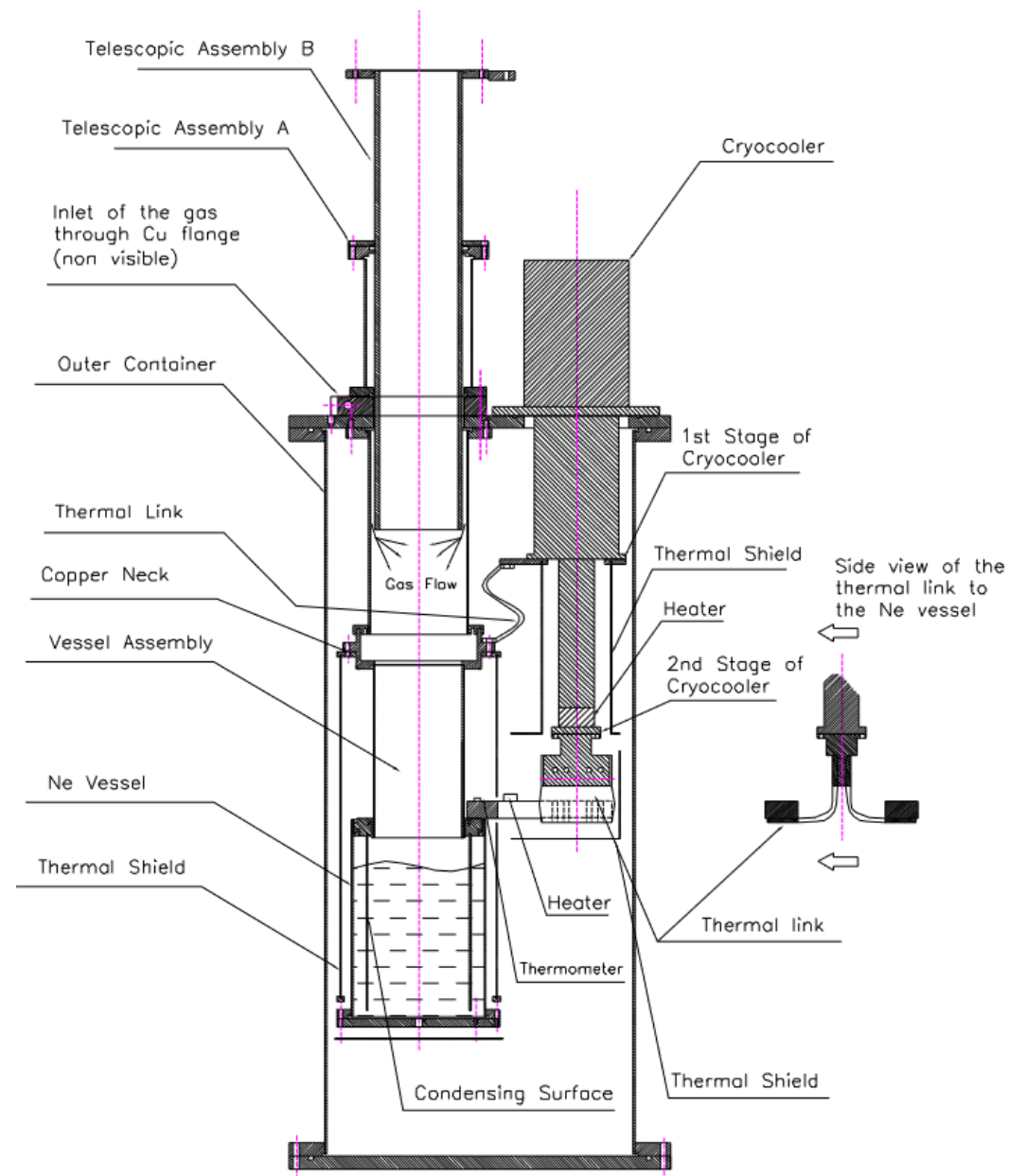
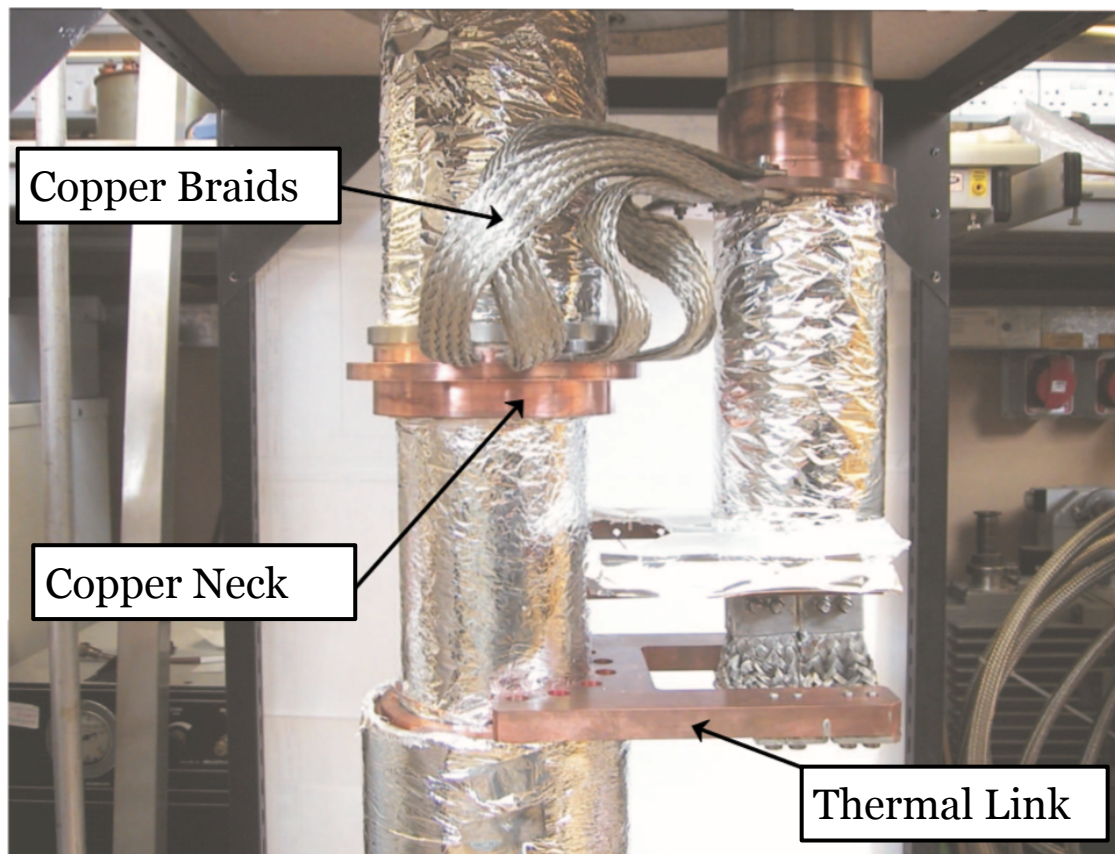

Liquid Chamber

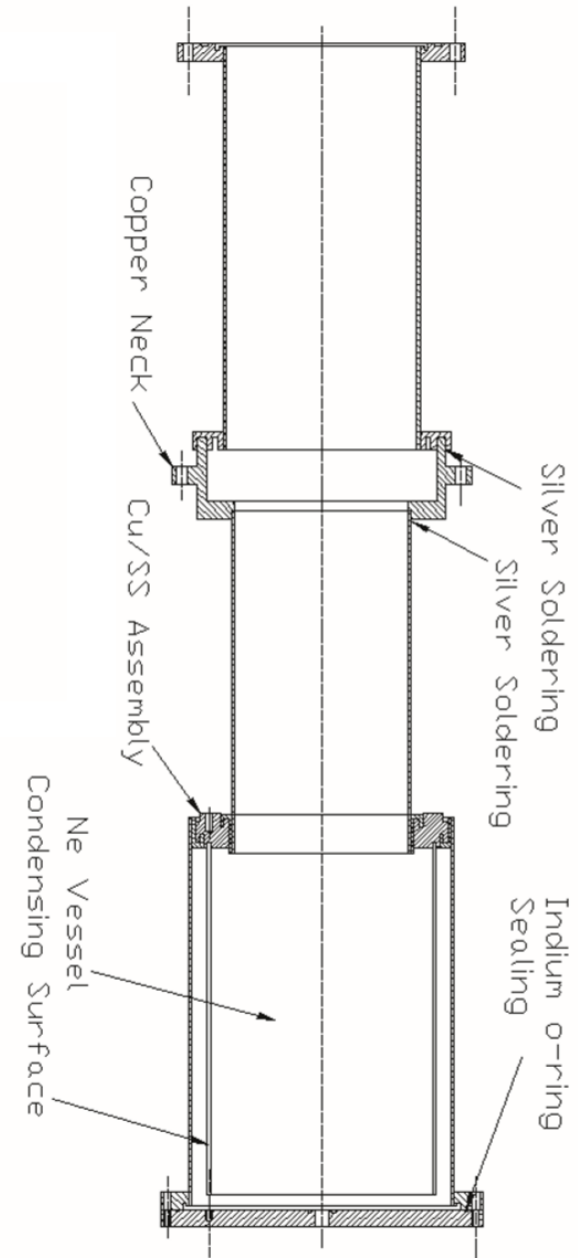
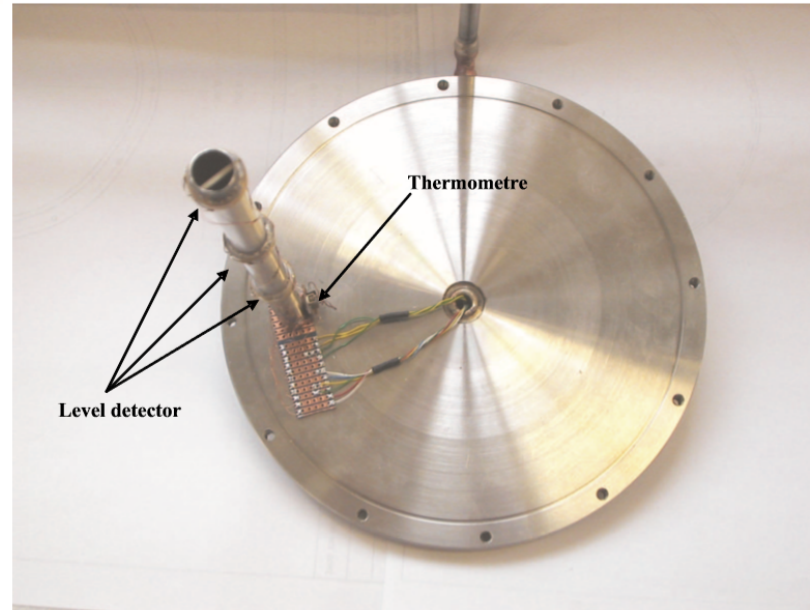
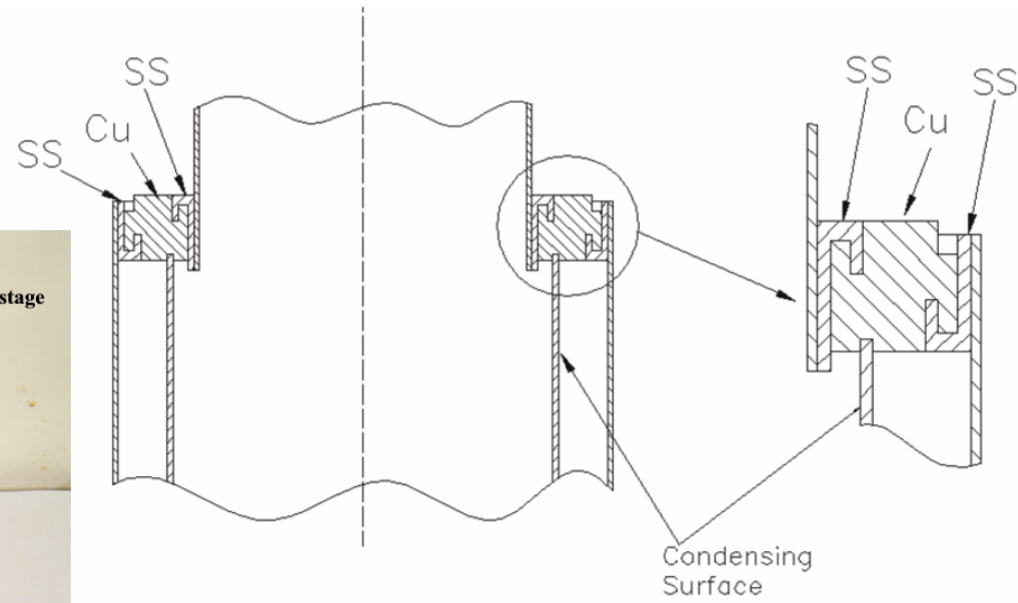
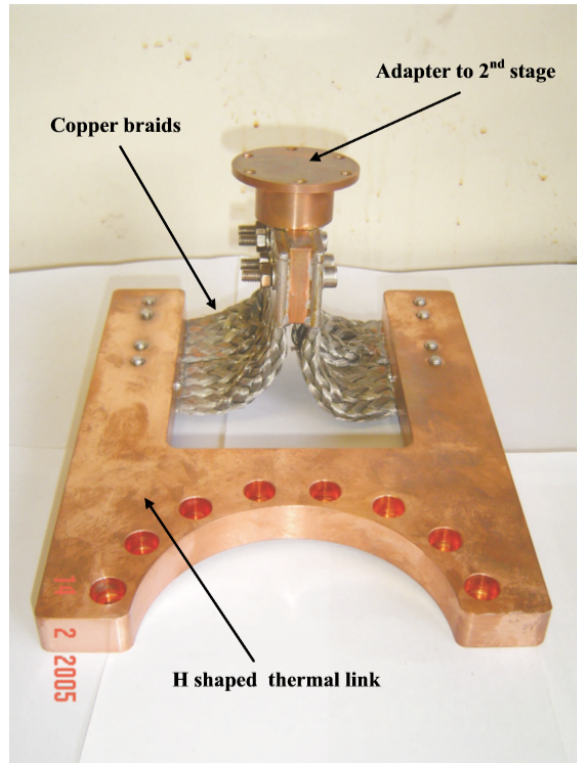

Current Leads

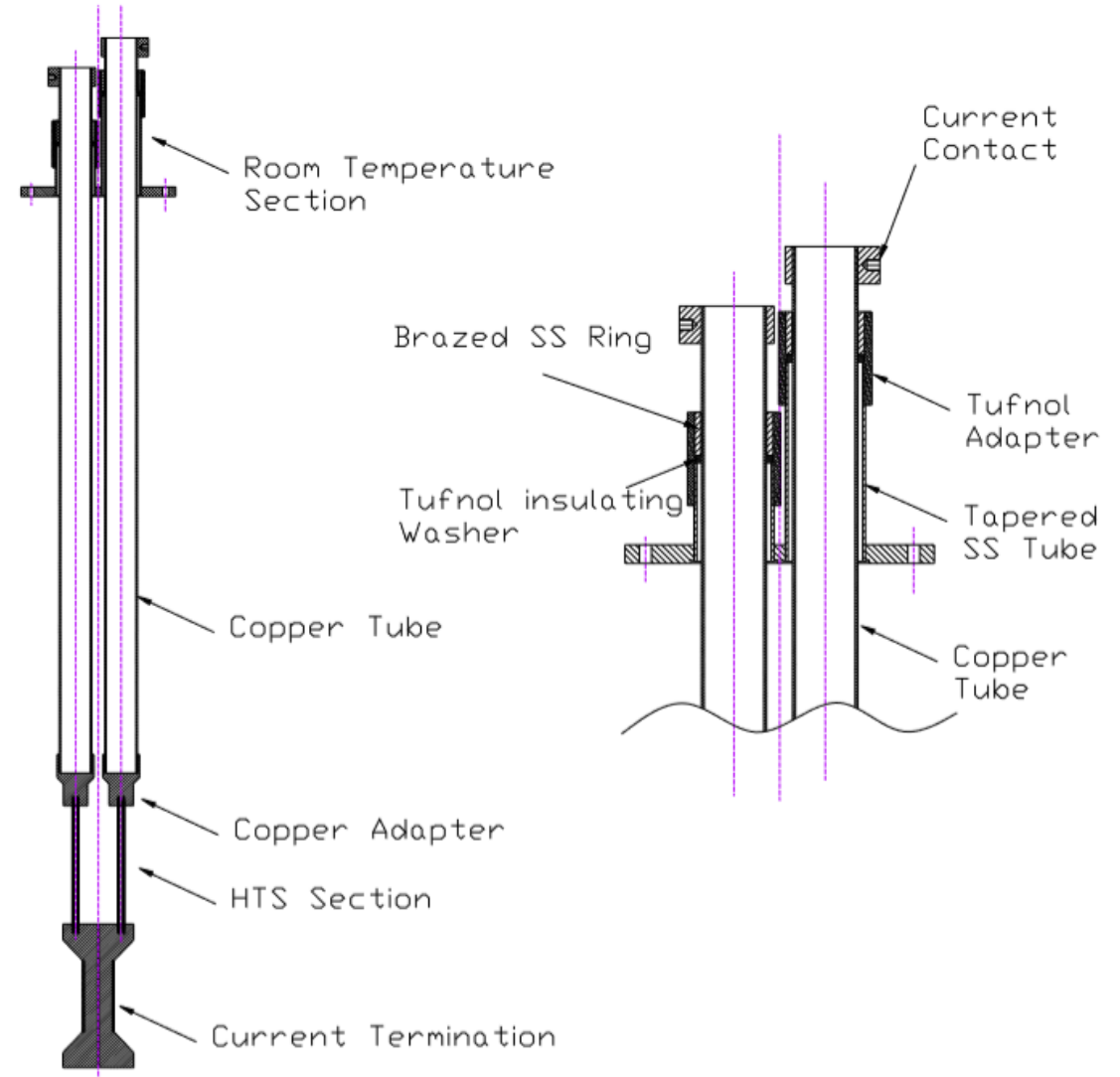
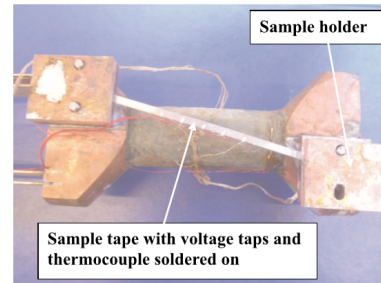
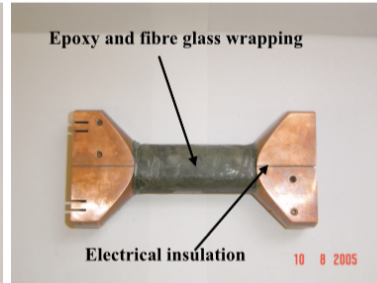
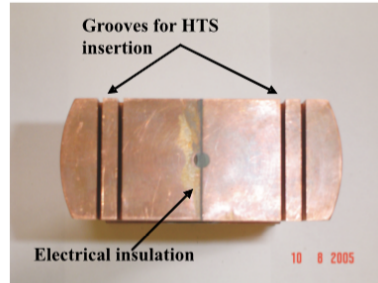
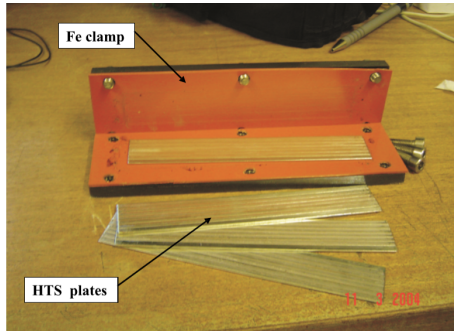
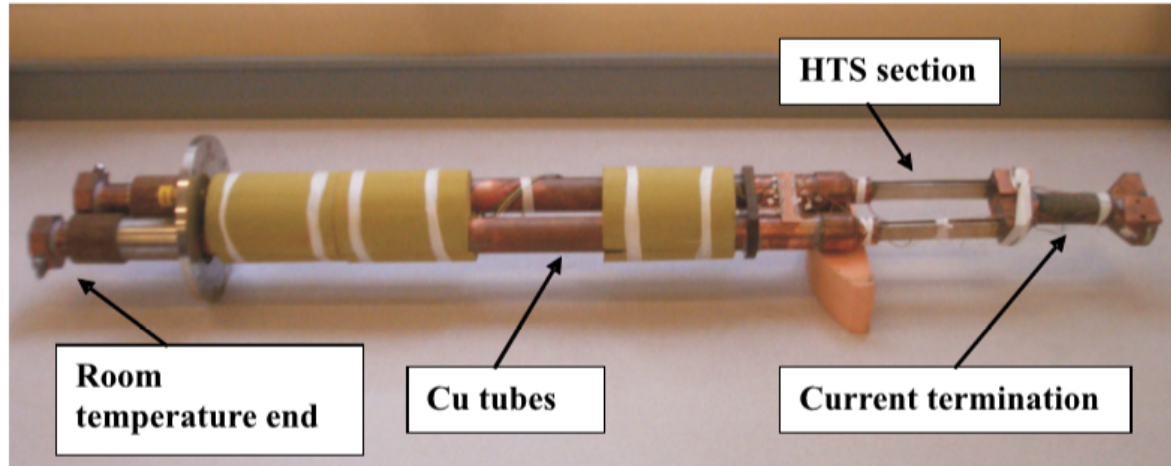

Telescopic Neck

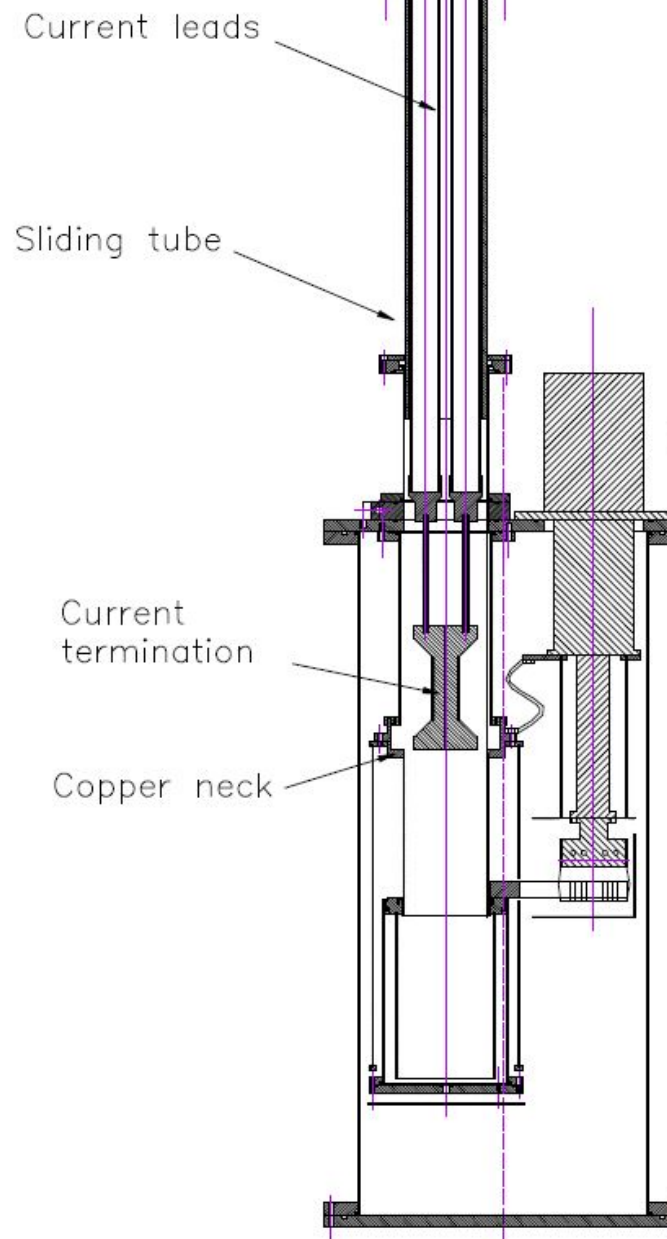
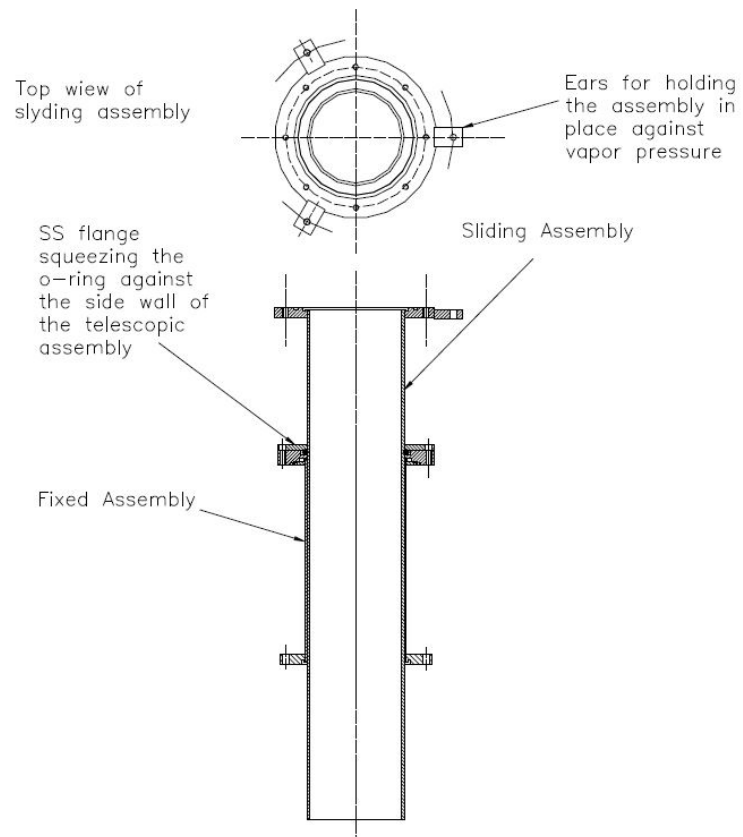

Cryocooler

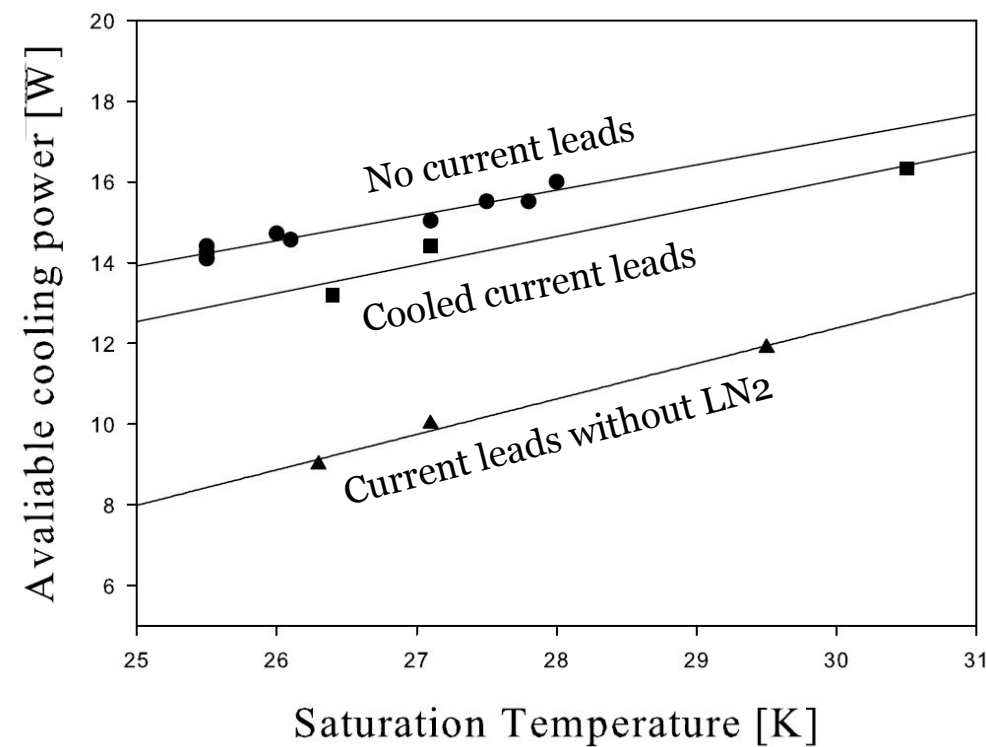

Transport Losses

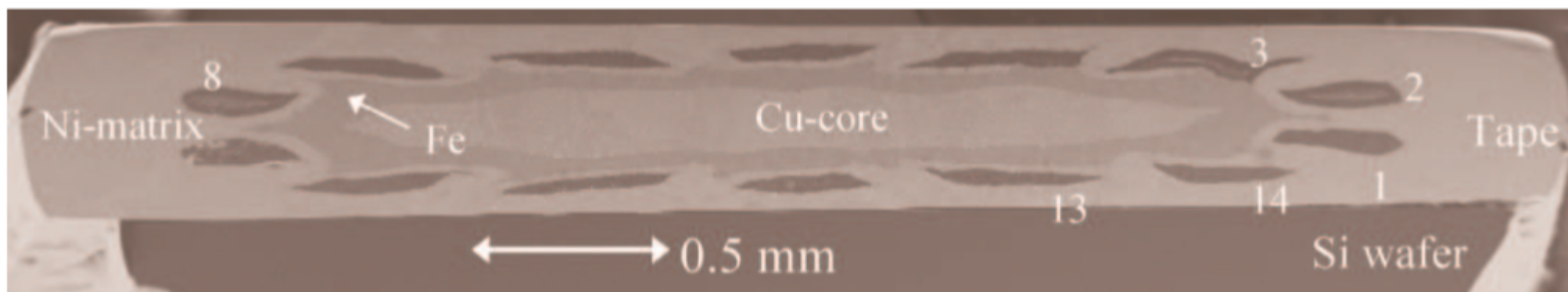
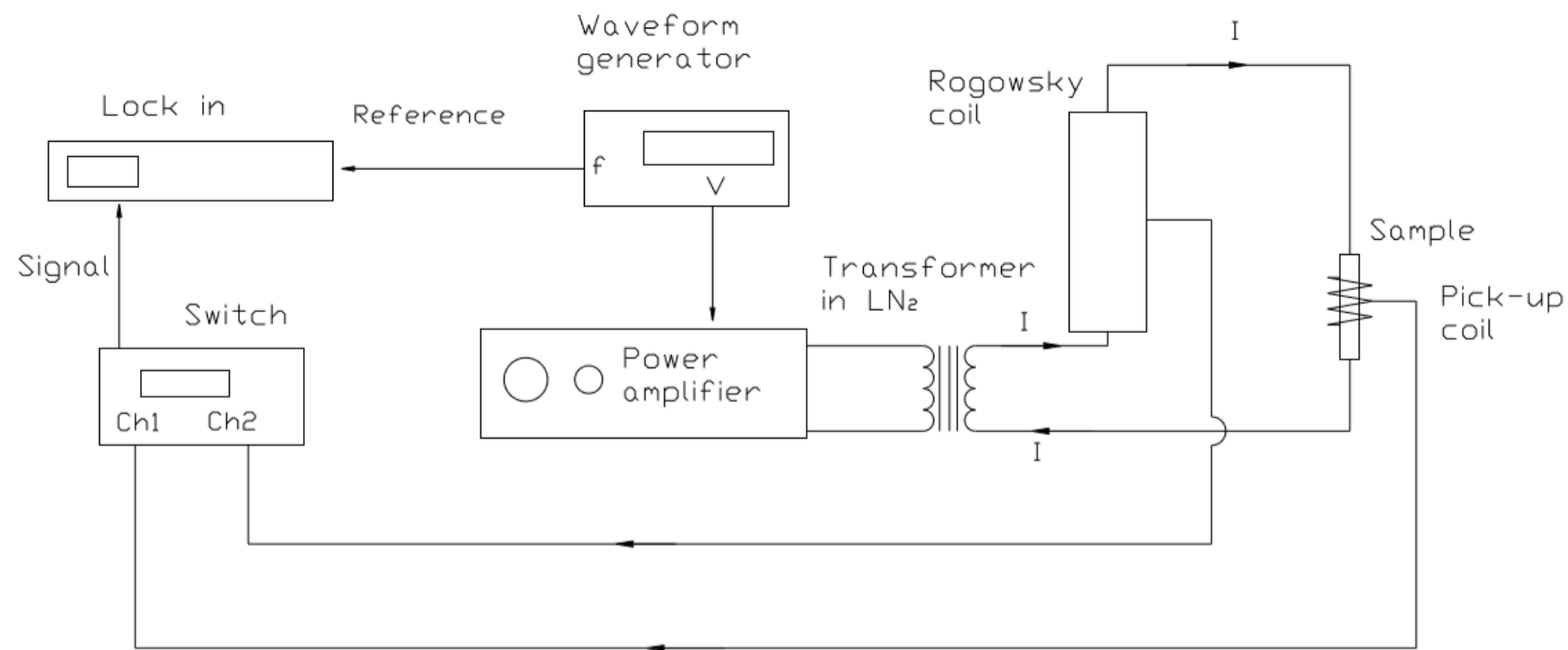

Transport Losses

Fixed Frequency

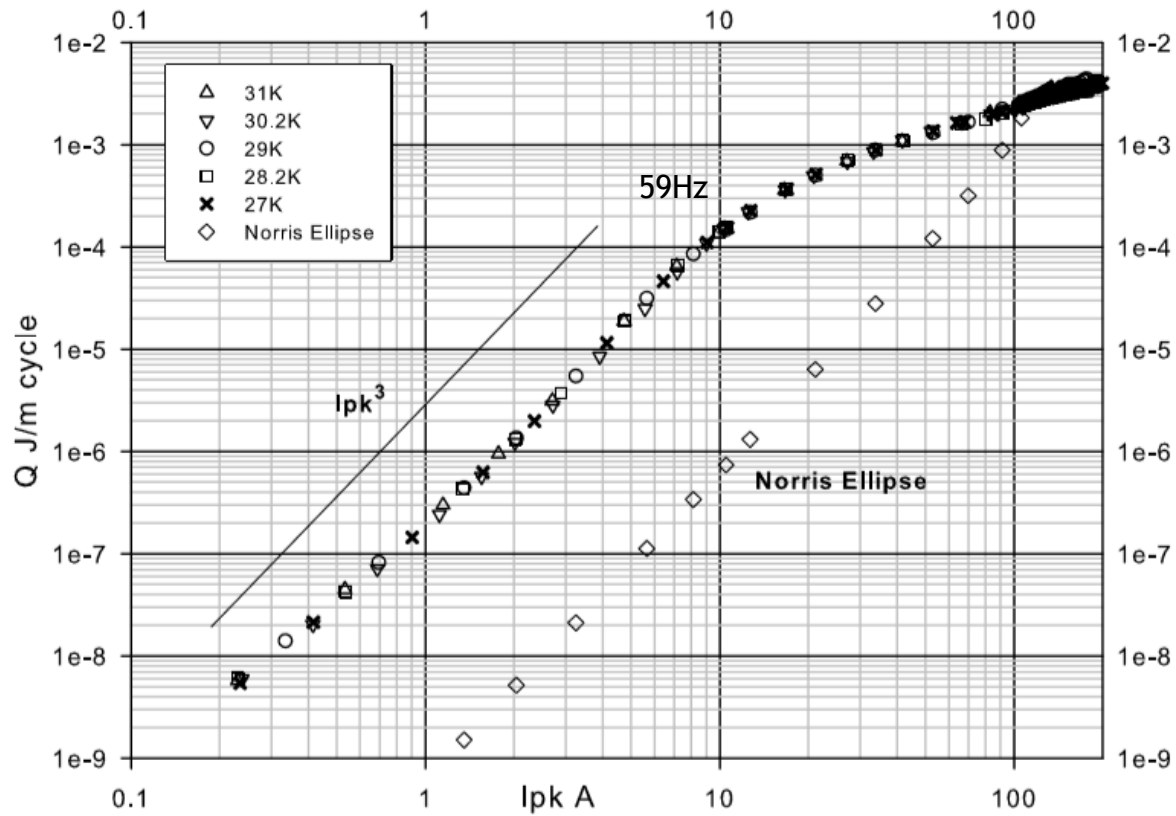

Variable Frequency

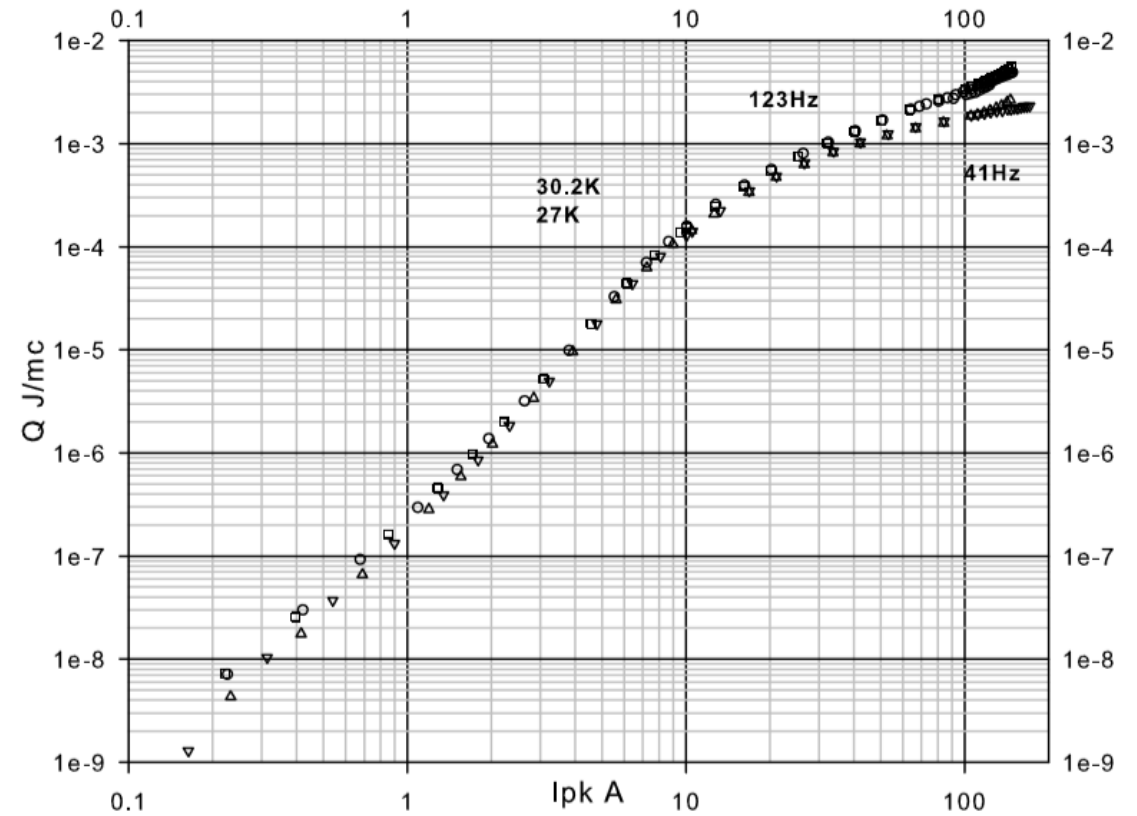

Transport Losses 3rd harmonic

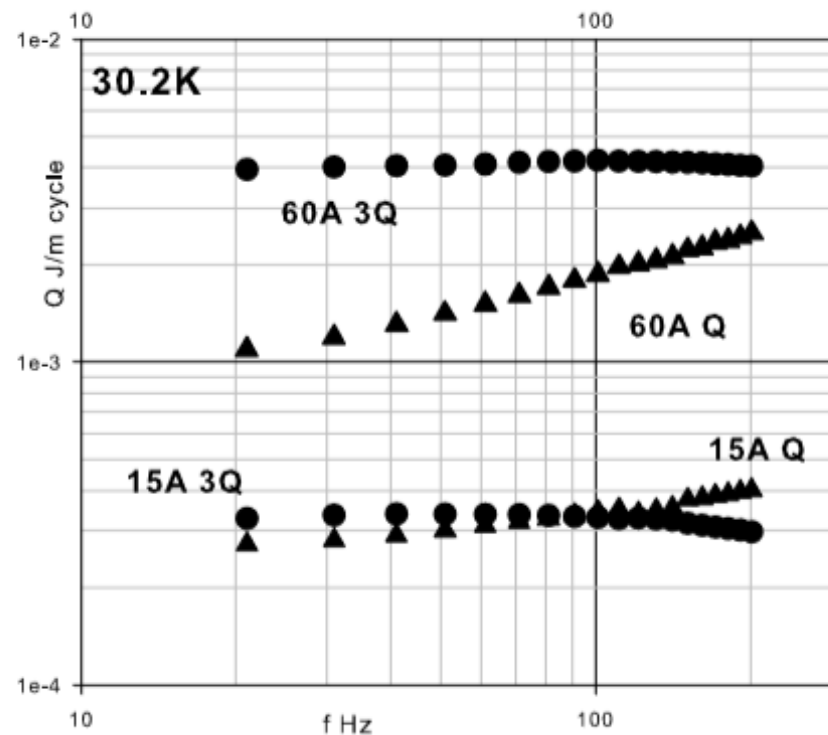
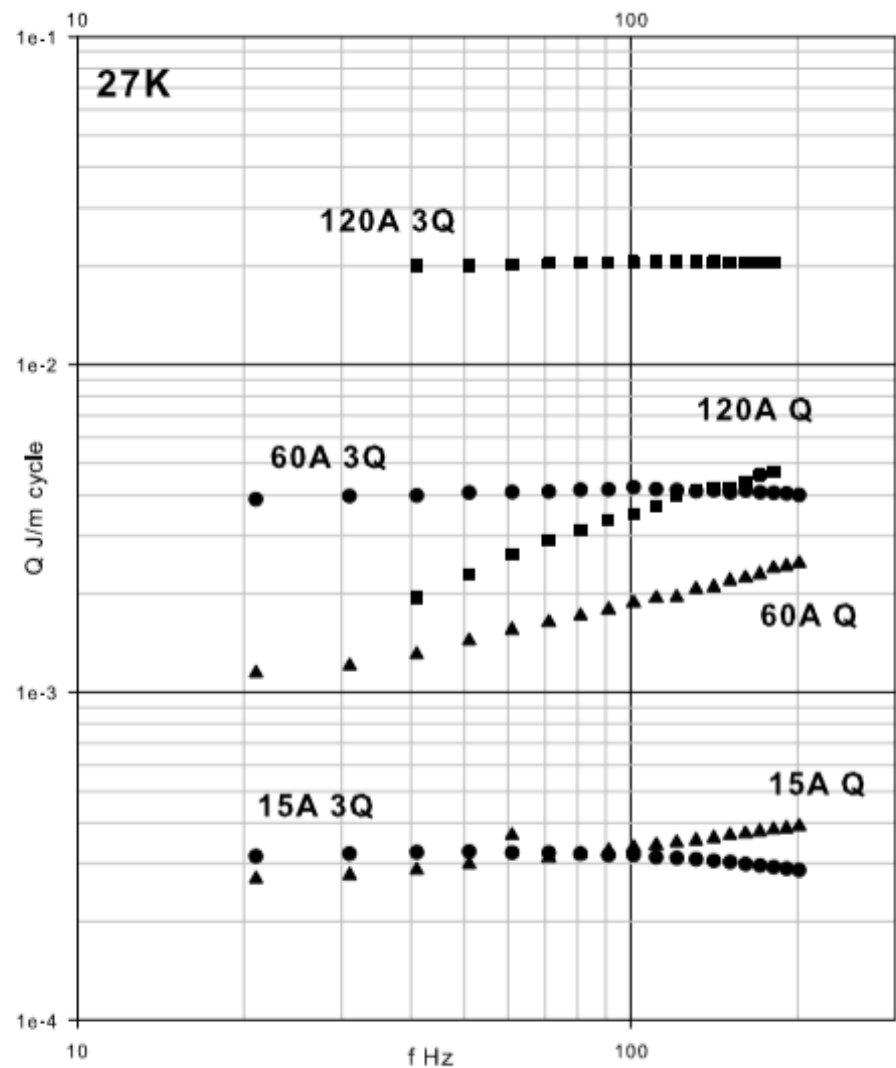

Transport Losses 3rd harmonic

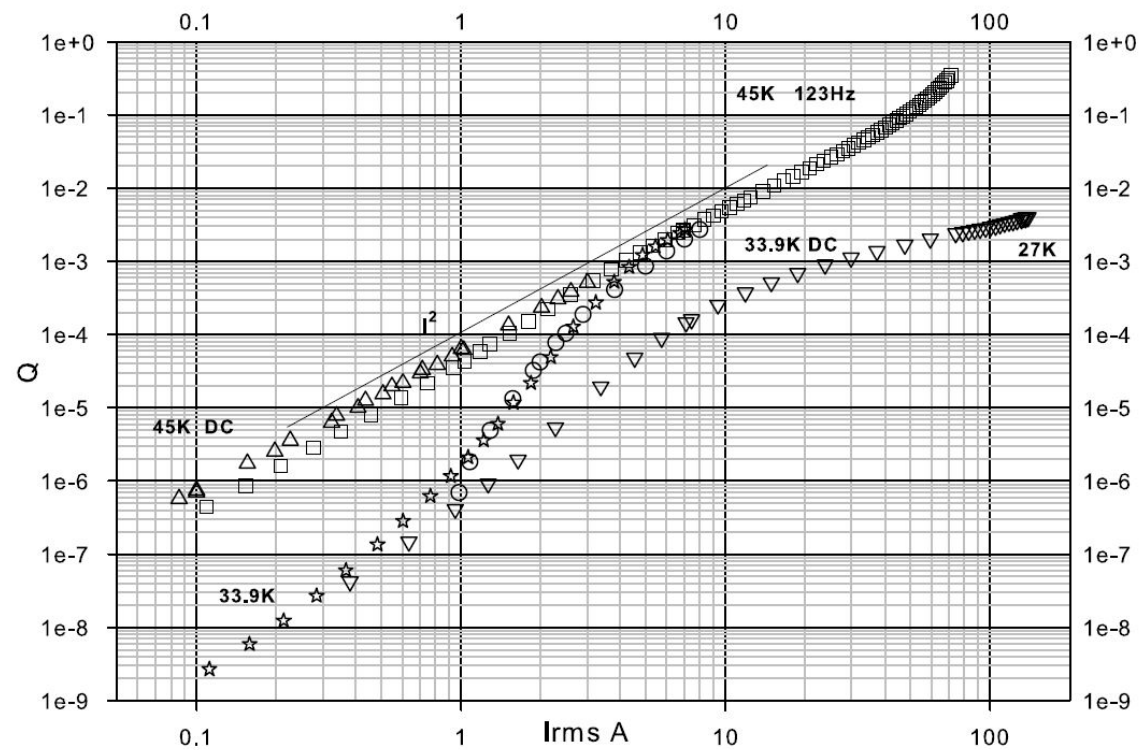
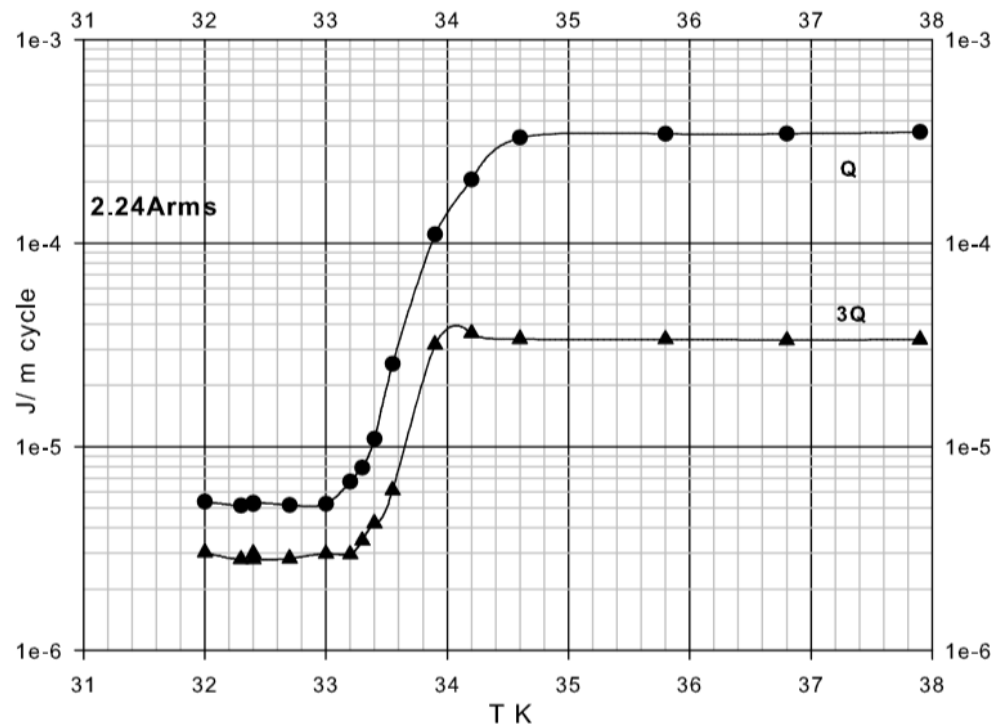

Thermal stability of conductors

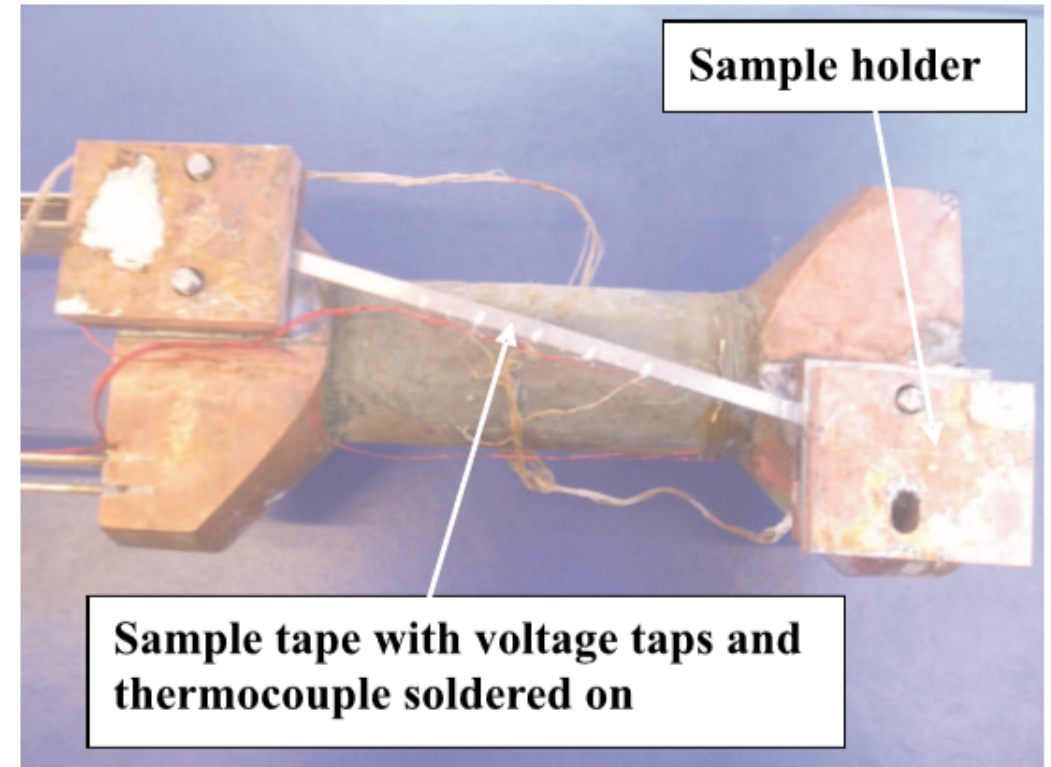
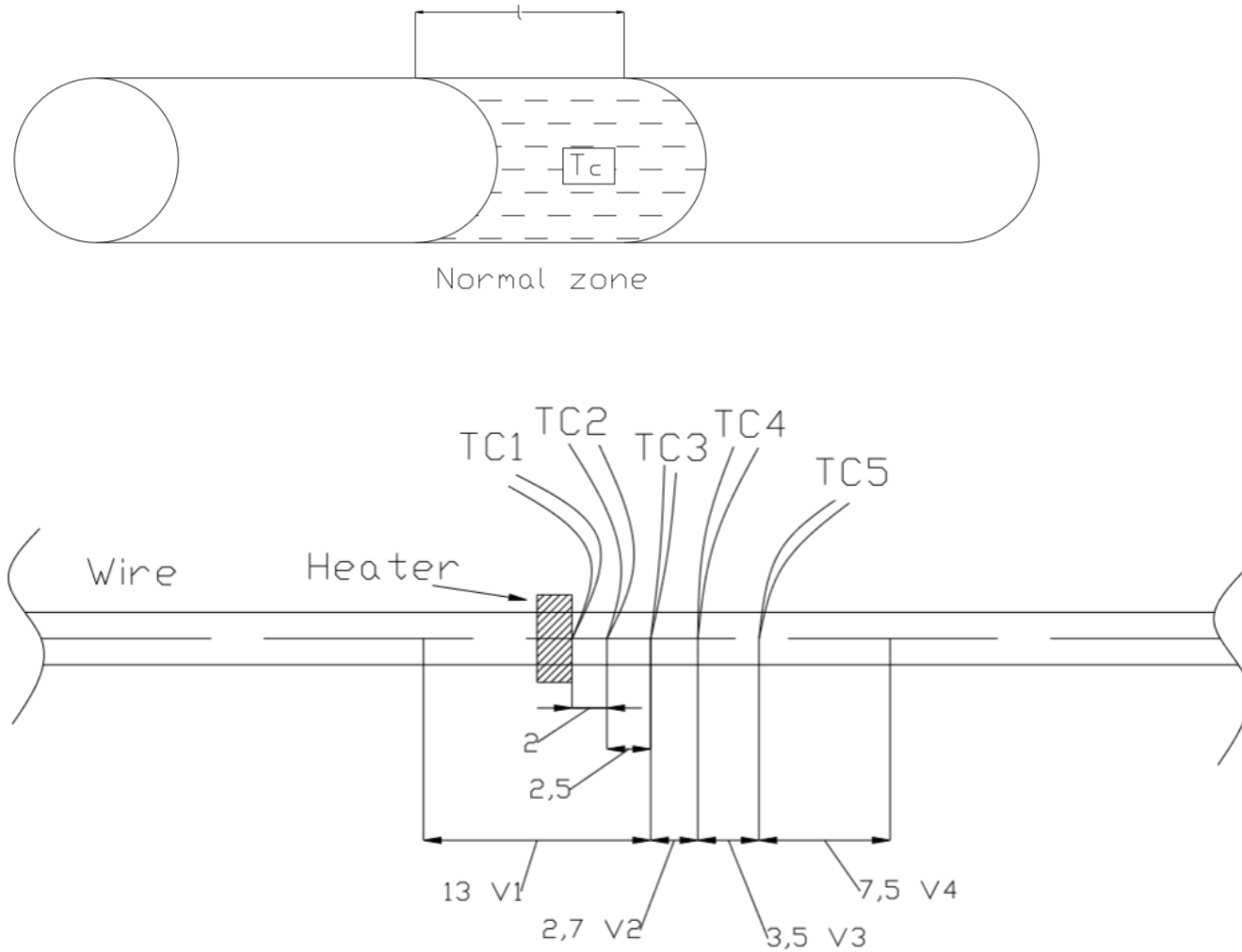

Stability Measurements

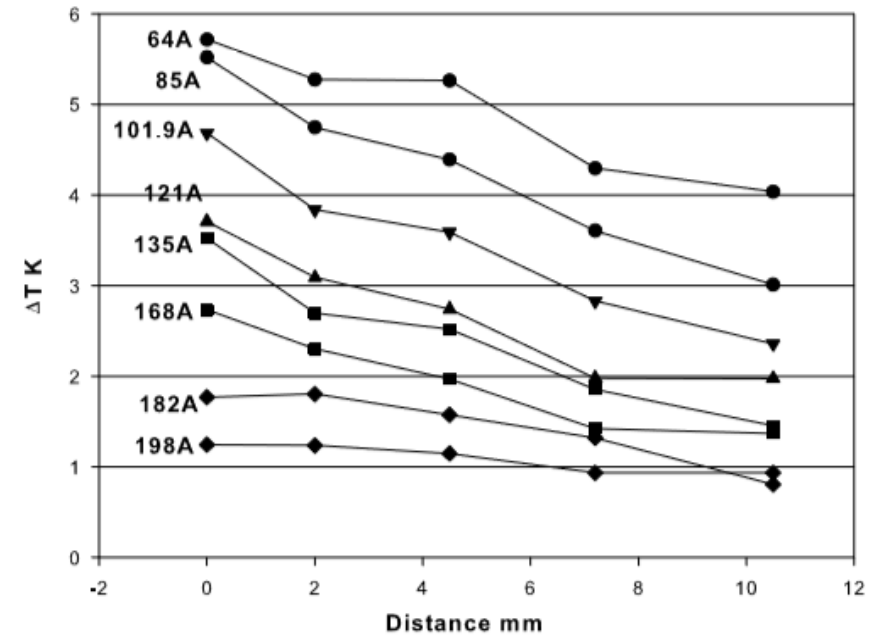
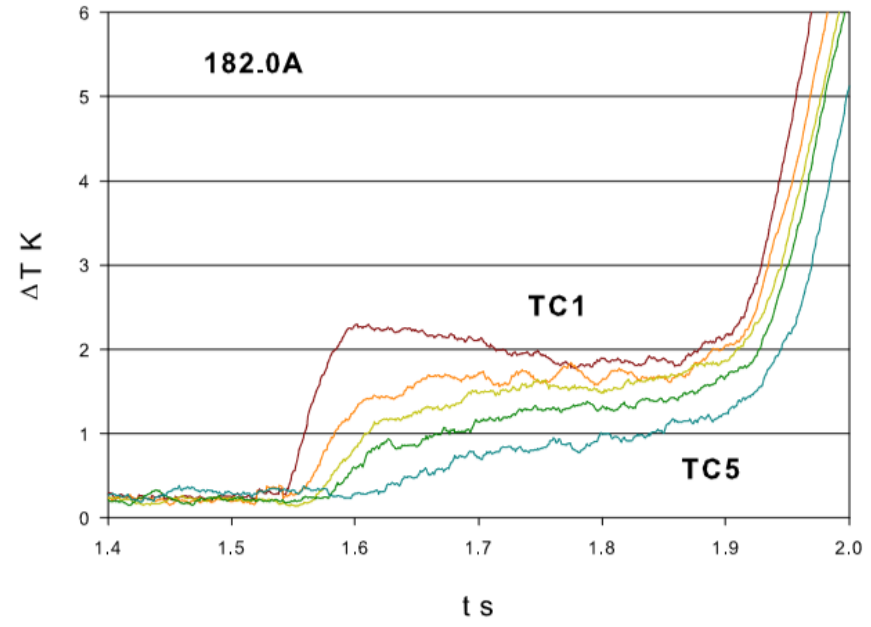
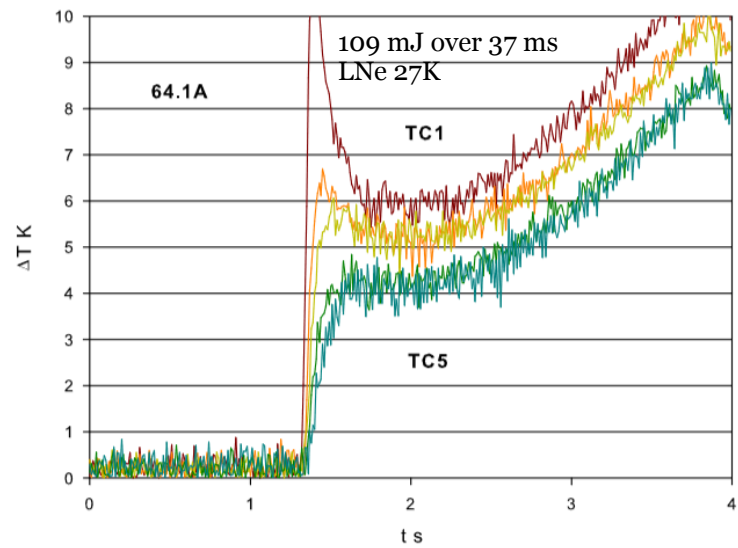
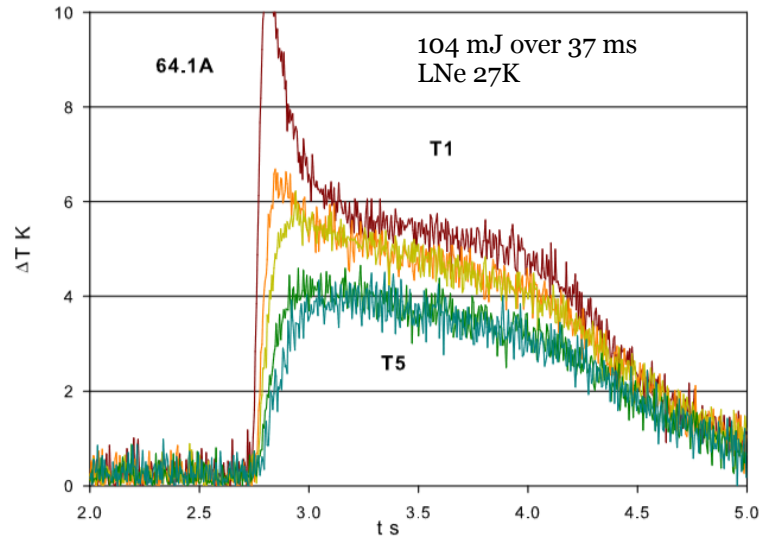

Stability Measurements

Transition temperature

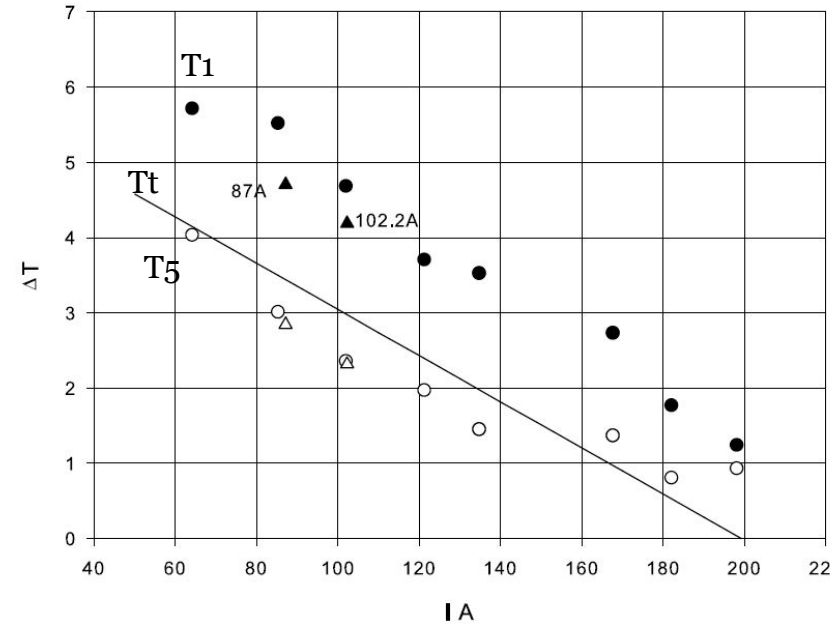

Dissipation

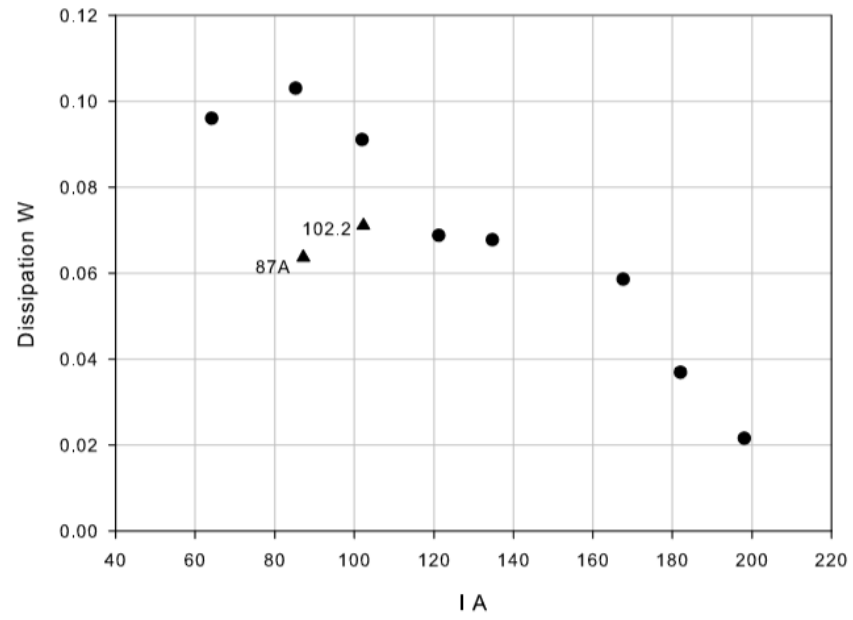

Minimum Quench Energy

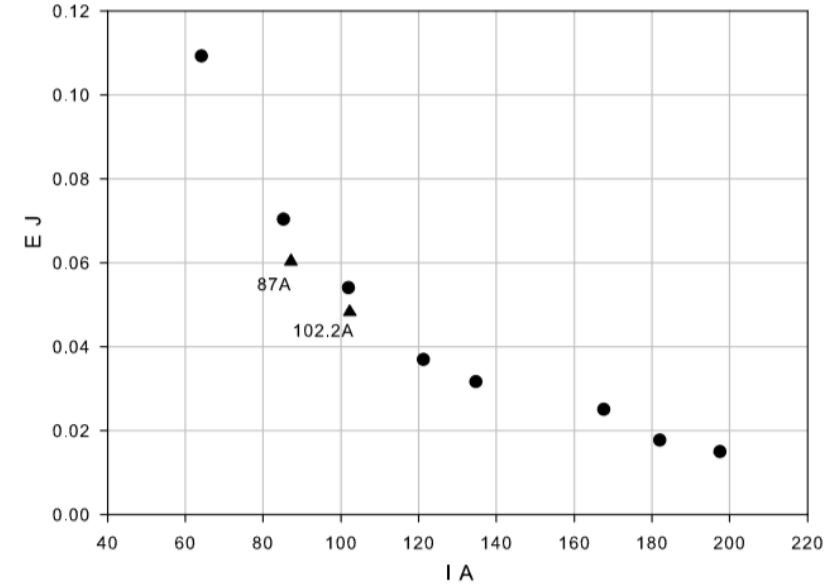

iFIN!